

# 360° ROTATOR

MODEL NUMBER

## R2437



# Class 2 360° Rotator R2437

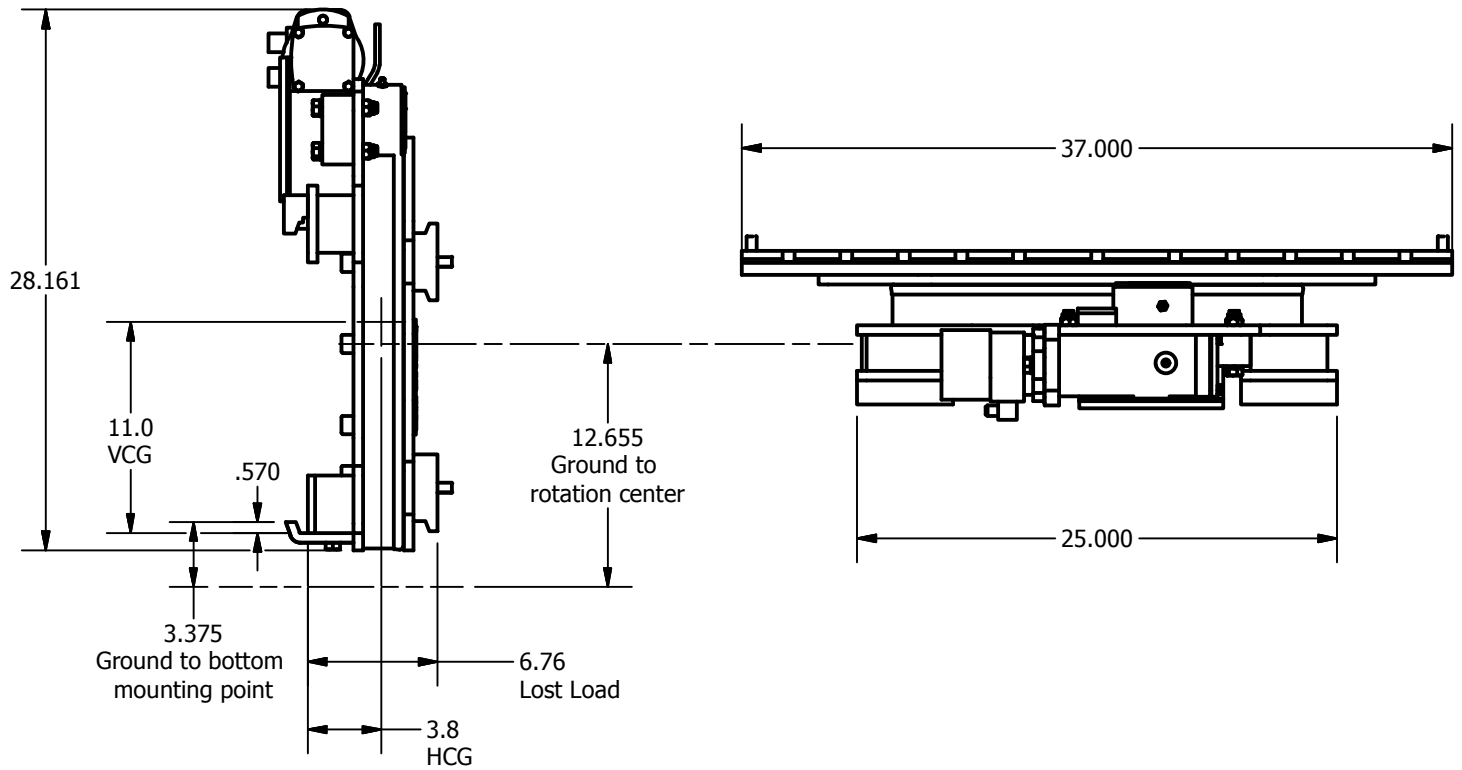

## Specifications

CAPACITY	4500 LBS @ 24" LOAD CENTER
MOUNTING	CLASS 2
LOWER LUG	BOLT-ON
OVERALL HEIGHT	28.16"
TOP LUG SPREAD	25.00"
WEIGHT	380 LBS
LOST LOAD	6.76
HORIZONTAL CENTER OF GRAVITY	3.8"
VERTICAL CENTER OF GRAVITY	11.0"
ROTATION	360 DEGREE CONTINUOUS
RECOMMENDED HYDRAULIC PRESSURE	1800 PSI
MAXIMUM HYDRAULIC PRESSURE	2500 PSI
MINIMUM HYDRAULIC FLOW	10.0 GPM
RECOMMENDED HYDRAULIC FLOW	10.0 GPM
MAXIMUM HYDRAULIC FLOW	12.0 GPM



# Class 2 Rotator Third Lug Installation

P/N: 91019022

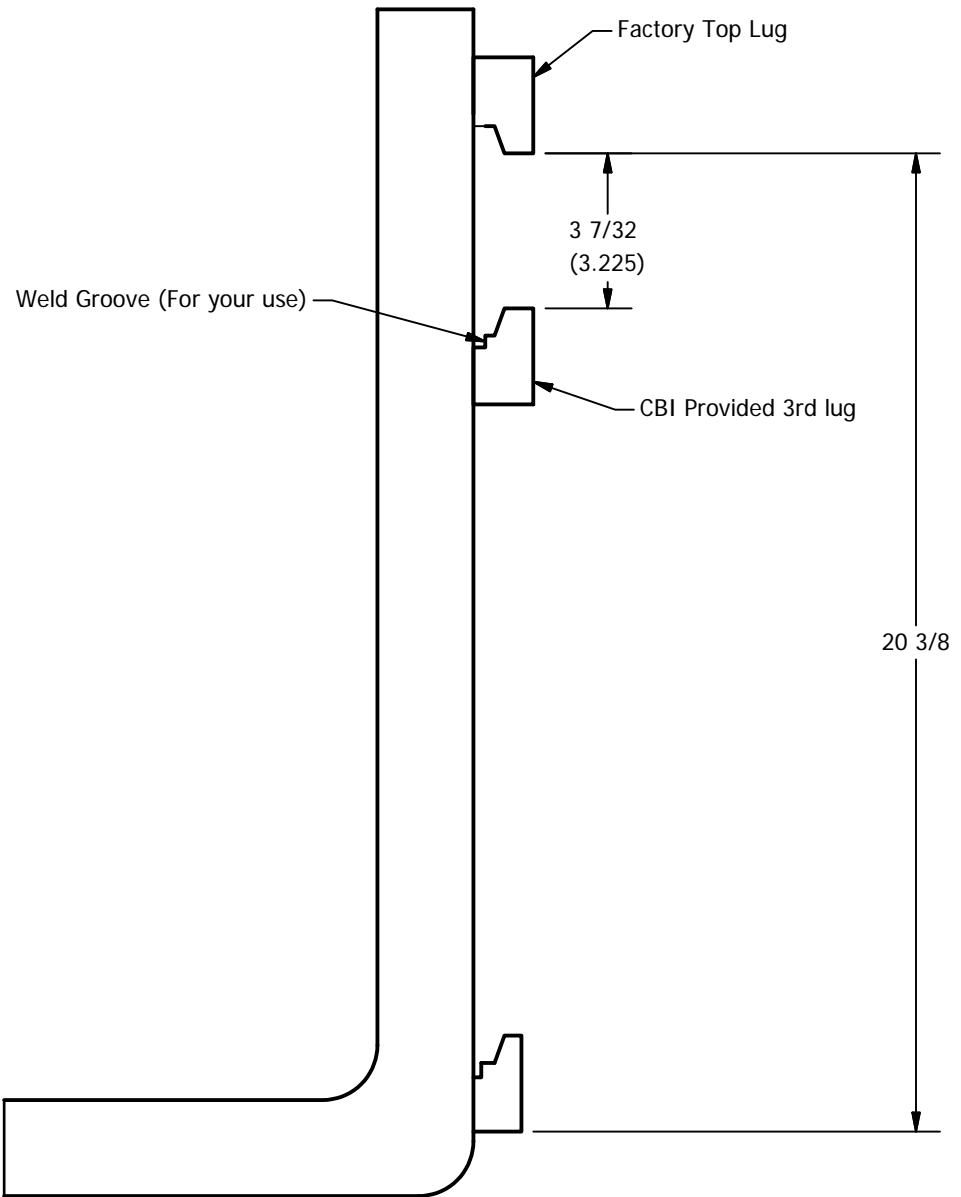



# CBI HYDRAULIC ATTACHMENTS MANUAL AND INFORMATION

## Attachment Information

Model Number: \_\_\_\_\_  
Description: \_\_\_\_\_  
Serial Number: \_\_\_\_\_  
Part Number: \_\_\_\_\_  
Date Shipped: \_\_\_\_\_

## Forklift Information

Model Number: \_\_\_\_\_  
Capacity: \_\_\_\_\_  
Mounting Class: \_\_\_\_\_

### Attachment ID plate:

Each CBI attachment is identified by a model number and serial number which is attached to the unit before shipment. This plate also includes capacity, and attachment weight.

### Forklift Capacity Plate:

Forklift capacity plate should be updated to include this specific attachment. The capacity of the truck and attachment combination may be less than the capacity for the forklift only.

### Service and Support:

We are here to help. For information about parts, service, or a warranty claim, call 1-800-547-3131 or reach us through email at [customerservice@cbimfg.com](mailto:customerservice@cbimfg.com)

### Warranty:

CBI products are warranted for one year. Products are guaranteed to be free from defects in material and workmanship and that, if the equipment or any part thereof is returned to an authorized dealer, transportation charges prepaid, and, if examination discloses to its satisfaction that the said equipment, part or parts has been defective in workmanship or material, CBI will deliver to purchaser without charge, transportation prepaid, parts of first class workmanship and material in exchange for any parts so found to be defective and its obligation is limited to said exchange. CBI shall not be liable for any repairs or alterations except those made with its written consent and shall not be liable for damages from delay or loss of use or for other indirect or consequential damages, losses or expenses of any kind. It is specifically agreed that the liability of CBI under all guarantees, either express or implied, is strictly limited to those terms as hereinbefore provided.



# CBI HYDRAULIC ATTACHMENTS MANUAL AND INFORMATION

## **Safety:**

- Check your equipment before you operate it.
- Check for hydraulic leaks.
- Never stand under attachment, or in operating range.
- Check for cracked hoses or fittings.
- Check for physical damage to the attachment. If any is found, report it before using.
- When removing demountable attachments always keep hands and feet free from dangerous positions and pinch points.
- Check to ensure that attachment is securely installed on forklift before use.
- Do not use the attachment for and other purpose than indicated.

## **Installation:**

Before installing the CBI Attachment on your lift truck, visually check to see that all fittings and hoses have not become damaged or loosened during shipment. Call to the attention of the carrier any obvious damage. This should be done immediately upon receipt.

Install the lines from the truck's hydraulics to the hydraulics of the attachment. If quick disconnect couplings are used jumper hoses may be required.

Hang attachment on truck, check to insure hoses are not kinked or pinched between truck carriage and attachment.

**ENSURE ATTACHMENT IS ATTACHED SECURELY TO FORKLIFT CARRIAGE. CHECK THAT ALL MOUNTING PARTS ARE PROPERLY INSTALLED.**

This attachment has been thoroughly tested before leaving our facility but, prior to placement into service, it should be operated continuously on the truck for several minutes to determine that all external connections are secure.

## **Truck Pressure:**

Maximum operating pressure for CBI Attachments is 2500 P.S.I. When forklift Hydraulic system pressures exceed this maximum, a relief valve is recommended on the attachment or auxiliary system of the truck. Consult your forklift dealer for more information.

## **Preventative Maintenance**

CBI Attachments have been constructed to require very little attention. But there are some measures which can be taken to ensure the long life of your CBI Equipment. Perform these checks monthly.

- Check to see that pivot points and vital components are clean and lubricated. Keeping pivot points, motors, gears, or transmissions greased with a graphite base grease will prevent excessive wear.
- Check all fittings and hoses. Be sure all fittings are tight, all hose connections are tight and check hoses for nicked or frayed areas.
- Check mounting parts for wear, repair or replace if needed.
- Check all bolts and welds for cracking, stress, or wear.

## **Repairs and required maintenance:**

Attachments should not be disassembled without first consulting your authorized CBI Attachments dealer. Replacement parts are available, and are listed in the pages that follow.



# Class 2 360° Rotator R2437

P/N: 91019022

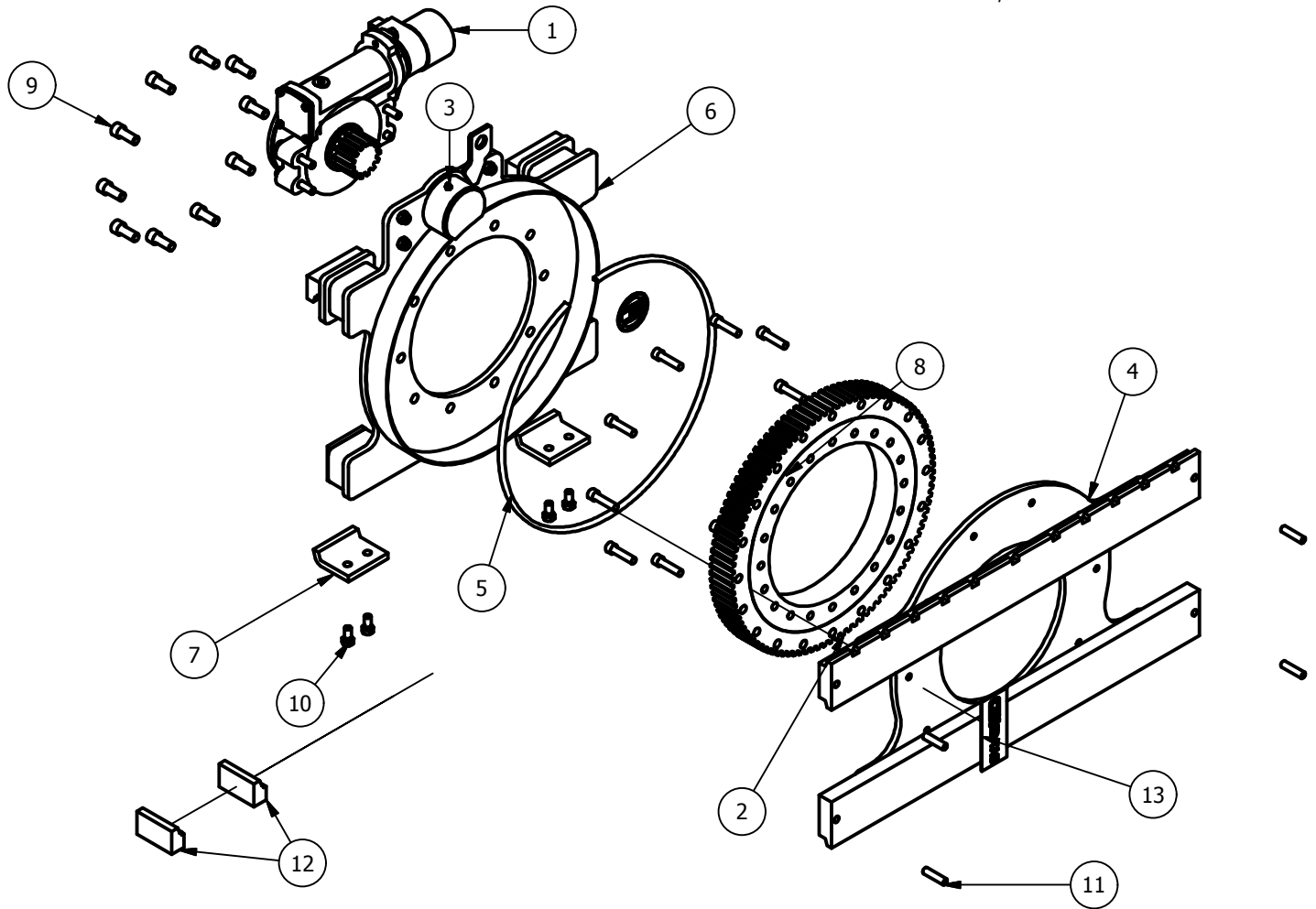

## PARTS LIST

ITEM	QTY	PART NUMBER	DESCRIPTION
1	1	70230022	Motor+Transmission Assembly - See Applicable Sheet
2	1	70201010	CBI Rotator Ring Gear
3	1	70150016	Zerk Grease Fitting
4	1	91019022B	Frontplate Assembly
5	1	76120001	Rotator Shroud Seal
6	1	91019022A	Backplate Assembly
7	2	91732999	Class 2 Bottom Rotator Lug
8	1	70111210	Front Plate Bolts (Set of 10) (110 ft-lbs)
9	1	70115810	Back Plate Bolts (10) (90 ft-lbs)
10	2	70111202	Bottom Lug Bolts (Set of 2)
11	4	70150020	Roll Pins
12	2	91732109	3rd Lug (Class II 3.5" Top Lug)
13	1	ID_TAG	CBI ID Tag



# CBI TRANSMISSION AND MOTOR ASSEMBLY REPLACEMENT PARTS

P/N: 70230022

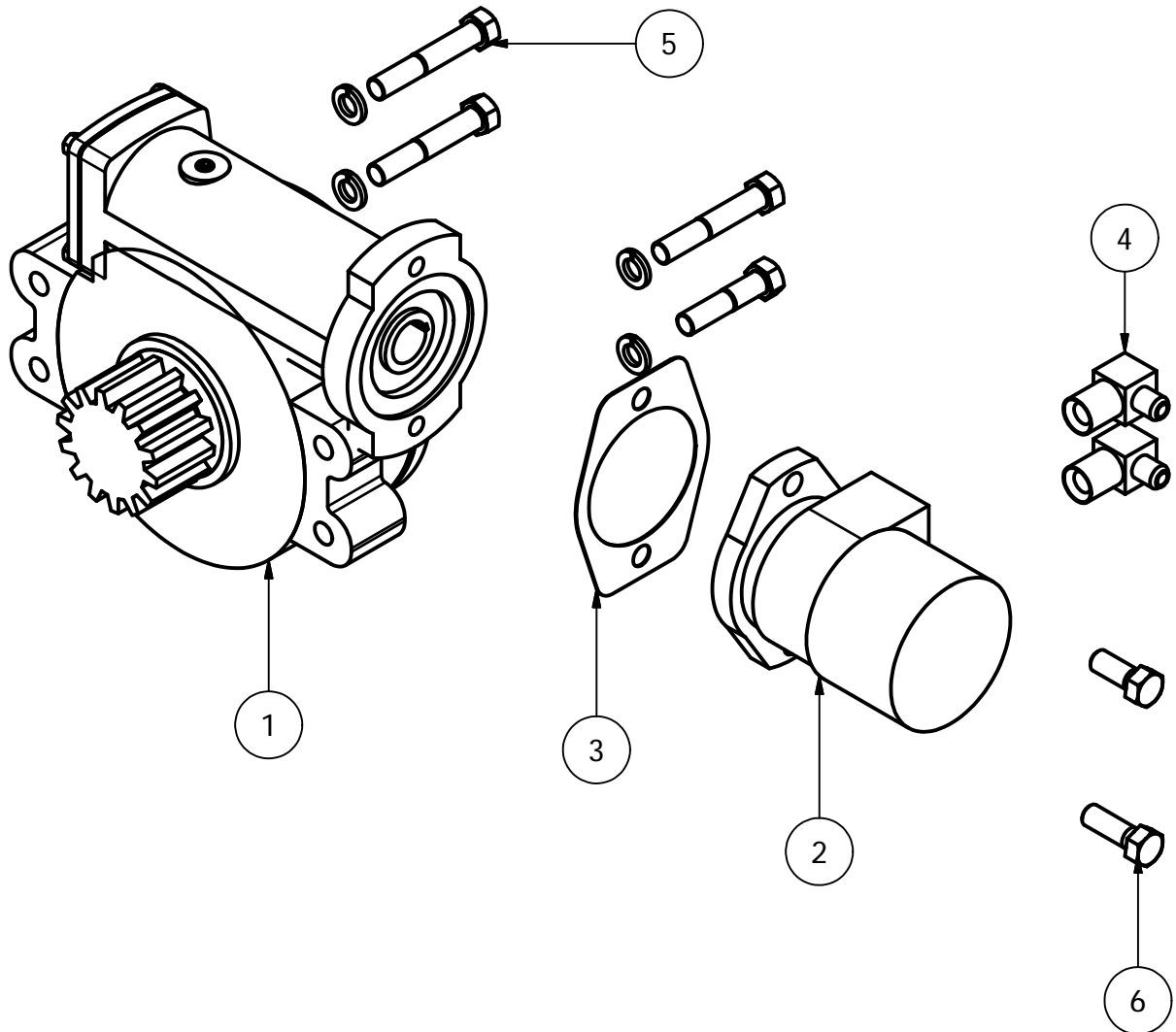

## PARTS LIST

ITEM	QTY	PART NUMBER	DESCRIPTION
1	1	70230002	CBI Transmission (See applicable page)
2	1	70230007	Class 2 Hydraulic Motor
3	1	70090104	Motor Gasket
4	2	70012007	90 Degree Hydraulic Fitting
5	1	70238831	Transmission Mounting hardware (set)
6	1	70238832	Motor Mounting Hardware (set)



# CBI TRANSMISSION REPLACEMENT PARTS

P/N: 70230000

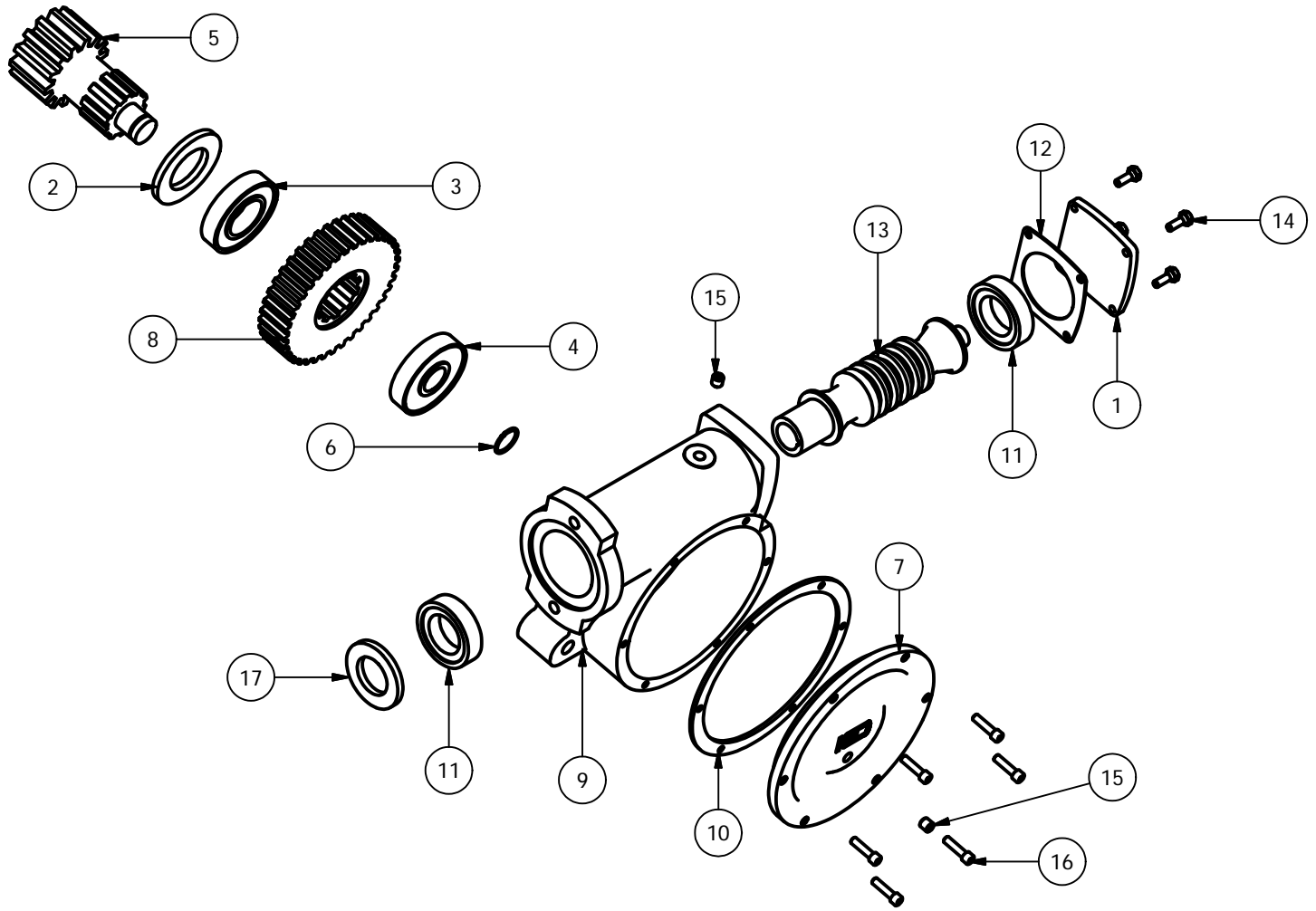

PARTS LIST			
ITEM	QTY	PART NUMBER	DESCRIPTION
1	1	70238817	End Cap
2	1	70238802	Shaft Seal
3	1	70238803	Shaft Bearing
4	1	70238805	Tail Bearing
5	1	70238801	Pinion Gear
6	1	70238806	Snap Ring
7	1	70238811	Case Cover
8	1	70238804	Worm Gear
9	1	70238800	Gear Case
10	1	70238810	Cover Gasket
11	2	70238807	T-Bearing
12	1	70238814	Cap Gasket
13	1	70238816	Worm
14	1	70238813	Cap Bolts
15	2	70238808	Case Plug
16	1	70238812	Cover Bolts
17	1	70238809	Worm Seal