

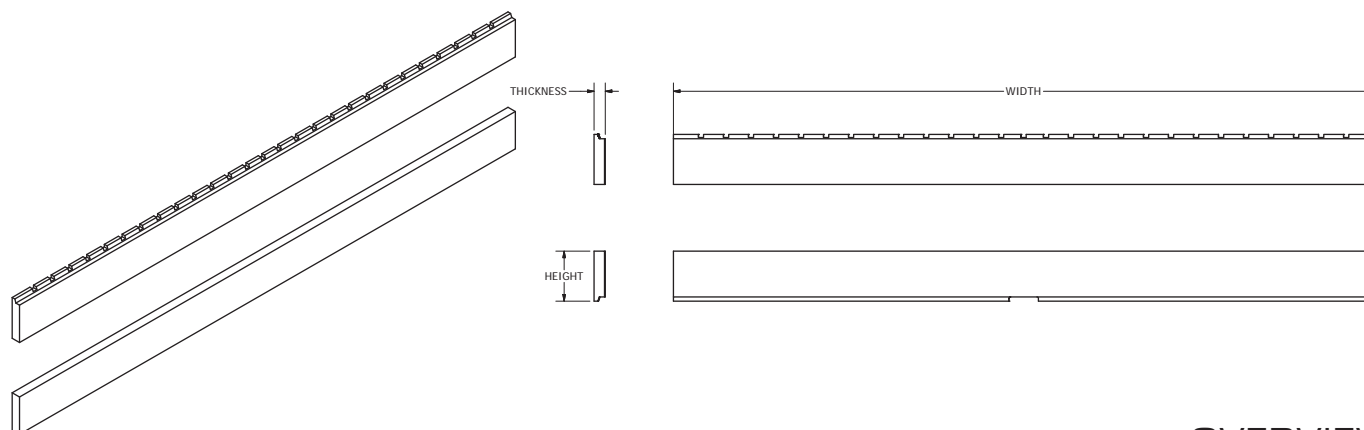

CARRIAGE PRODUCTS

CARRIAGE BARS



OVERVIEW

CBI Carriage Bars are manufactured using quality alloy steel. Replacement carriage bars are available in both standard sizes (see below), or to customer specifications. Call customer service for a free quote.

FEATURES

Manufactured to ITA specifications
Quality alloy steel

SPECIFICATIONS

Model Number	Description	Weight Per Linear Inch
Class II - 1 1/4" X 6"		
CBT-2-N	Class II top bar with notches	2.12
CBT-2-B	Class II top bar without notches	2.12
CBB-2-N	Class II bottom bar with center notch	1.91
CBB-2-B	Class II Bottom Bar w/o center notch	2.02
CBTR-2-N	Class II top bar, double cut bar with notches (Rotators)	1.8
Class III - 1 1/2" X 6"		
CBT-3-N	Class III top bar with notches	2.547
CBT-3-B	Class III top bar without notches	2.5
CBB-3-N	Class III bottom bar with center notch	2.3
CBB-3-B	Class III bottom bar w/o center notch	2.42
CBTR-3-N	Class III top bar, double cut bar with notches (Rotators)	2.17
Class IV - 2" X 7"		
CBT-4-N	Class IV top bar with notches	4
CBT-4-B	Class IV top bar without notches	4
CBB-4-N	Class IV bottom bar with center notch	4
CBB-4-B	Class IV bottom bar without center notch	4
CBTR-4-N	Class IV top bar, double cut with notches (Rotators)	3

