

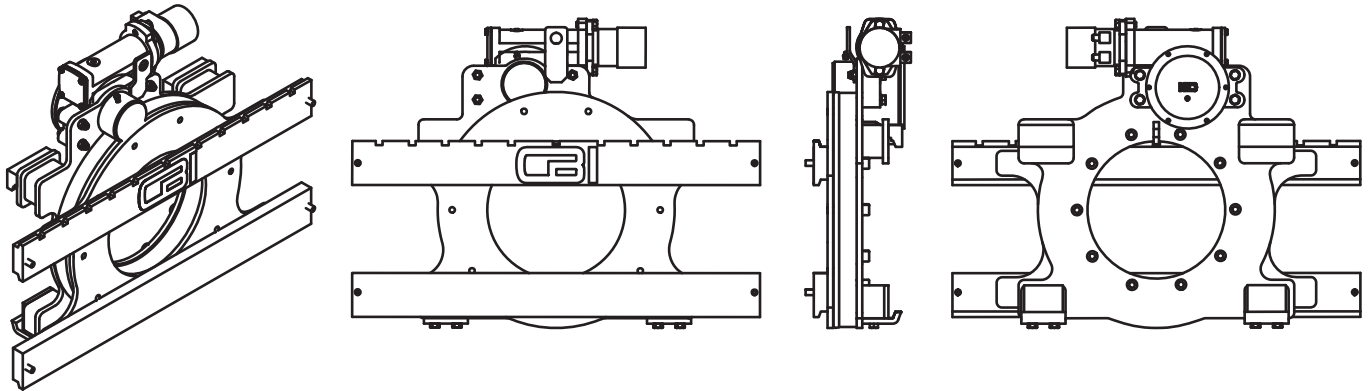

HYDRAULIC ATTACHMENTS

ROTATOR

A



OVERVIEW

CBI rotators are a cost effective way to add rotating function to your forklift. Rotators are used for dumping bins and totes. CBI rotators offer quality and reliability..

FEATURES

- 360 Degree Rotation
- Third Lug For Forks Included
- Heavy Duty Bearing Assembly
- Heavy Duty Transmission & Pinion gear
- Lifting Eye for easy installation
- Easy Access Lubrication Points
- (New!) Better Visibility
- (New!) Lighter Weight

OPTIONS

- Pin Mount
- Special Mounting Options
- Wider Fork Bars available

SPECIFICATIONS

Model Number	Weight	Mounting	Capacity	Rotation Speed	Lost Load	HCG	VCG	Fork Bars	Req. Hyd. Flow
CBI R2 437	380	II	4500 @ 24" LC	5.0 RPM	6.76"	3.8	11"	37"	10 TO 12 GPM
CBI R2 542	570	III	6000 @ 24" LC	5.0 RPM	7.26"	4.4"	12.1"	42"	10 TO 12 GPM
CBI R2 542C	590	II/III	6000 @ 24" LC	5.0 RPM	7.26"	4.3"	12"	42"	10 TO 12 GPM
CBI R2 742	600	III	7500 @ 24" LC	4 RPM	7.26"	4.5"	15"	42"	10 TO 12 GPM

RELATED PRODUCTS

- Hydracoil, Electricoil page F-1
- Waterman Solenoid Valve Page G-3